

COMPOSITE REPAIR

INTRODUCTION

Composites are used in a wide range of applications in aerospace, marine, automotive, surface transport and sports equipment markets. Damage to composite components is not always visible to the naked eye and the extent of damage is best determined for structural components by suitable Non Destructive Test (NDT) methods.

Alternatively the damaged areas can be located by simply tapping the composite surface and listening to the sound. The damaged areas give a dull response to the tapping, and the boundary between the good and damaged composite can easily be mapped to identify the area for repair.

Awareness of and inspection for composite damage should be included in the regular maintenance schedules for composite structures. Particular attention would be made to areas which are more prone to damage.

Repairs to aircraft structures are controlled and should be carried out according to the Aircraft Structural Repair Manual (SRM). For other applications the repaired components would normally be expected to meet the original specification and mechanical performance requirements.

This guide aims to give a general approach to composite repair in all applications and will examine both sandwich and laminate structures.

Sandwich Structures

Thin, high strength skins are separated by, and bonded to, lightweight honeycomb cores; the thicker the core the stiffer the panel with minimal weight increase.

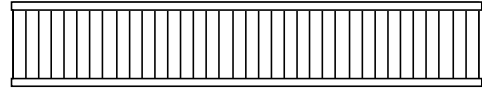

Laminate Structures

Laminate structures are assembled so that the fibre orientation provides most of the desired mechanical properties and the matrix largely determines the environmental performance.

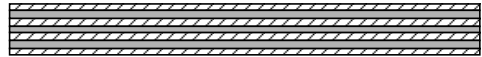

April 1999
Publication No. UTC 102

® Hexcel Registered Trademark
© Hexcel Composites, Duxford



COMPOSITE REPAIR

REPAIR FLOW CHART

The flow chart gives the key stages for composite repair.

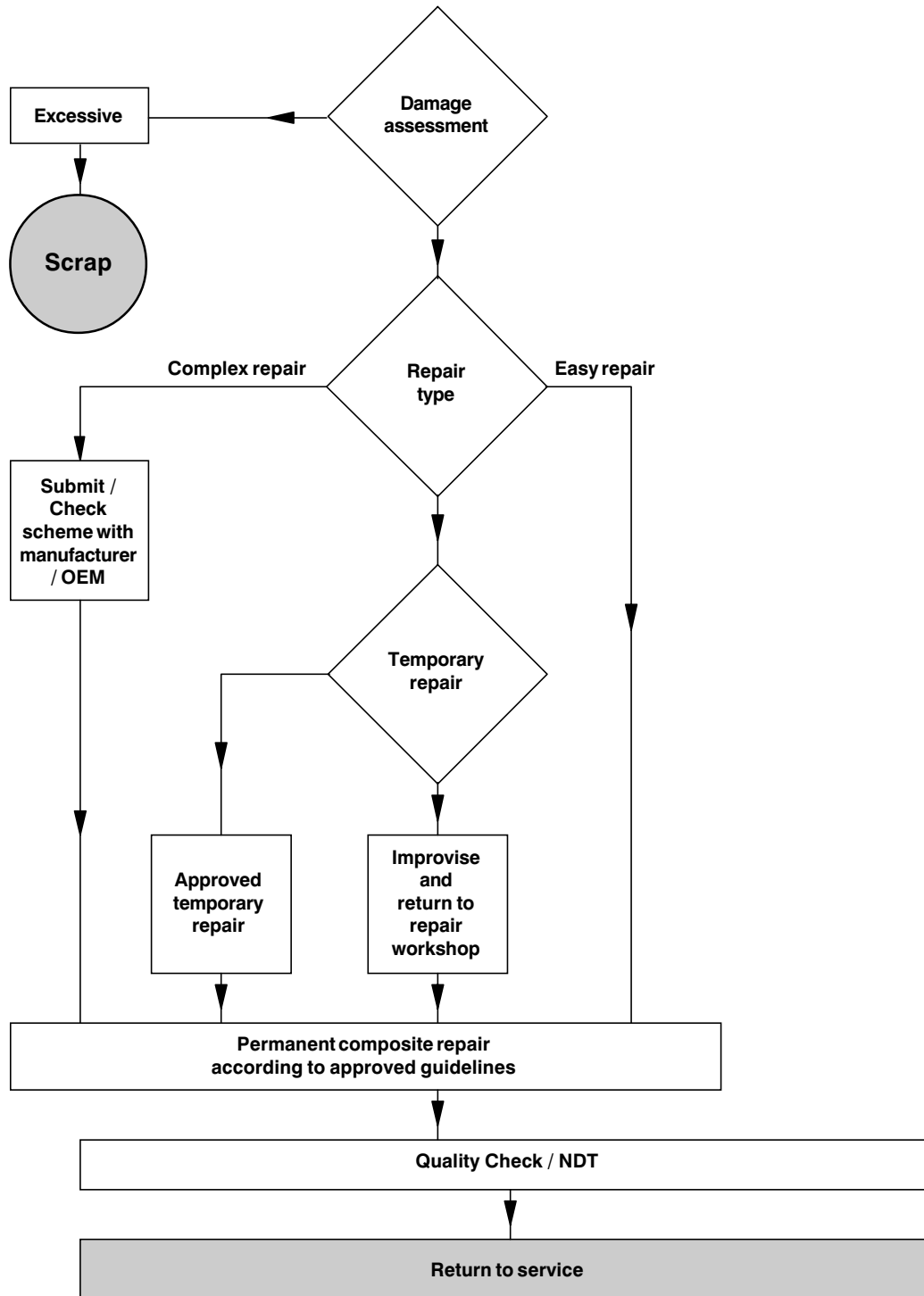

KEY STAGES OF COMPOSITE REPAIR



Some damage to composites is obvious and easily assessed but in some cases the damage may first appear quite small, although the real damage is very much greater. Impact damage to a fibre can appear as a small dent on the reinforced composite surface but the underlying damage can be much more extensive.

The decision to repair or scrap is determined by considering the extent of repair needed to replace the original structural performance of the composite. Other considerations are the repair costs, the position and accessibility of the damage and the availability of suitable repair materials.

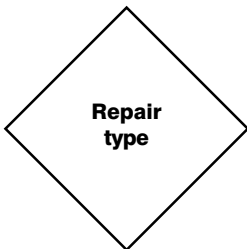

Easy repairs are usually small or do not effect the structural integrity of the component. These repairs are made by following the simple guidelines indicated for laminate or sandwich panels (*see repair sections*).

Complex repairs are needed when the damage is extensive and needs to replace the structural performance of the component. The best choice of materials would be to use the original fibres, fabrics and matrix resin. Any alternative would need careful consideration of the service environment of the repaired composite, i.e. hot, wet and mechanical performance.

The proposed repair scheme should meet all the original design requirements for the structure.

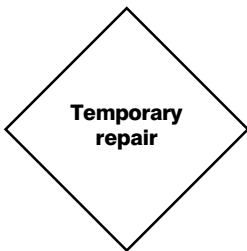

When a composite repair is needed for components in use. Some repairs need the specialist equipment of the workshop and some form of improvised repair is needed to return the component to a suitable repair workshop. A **temporary repair**, usually in the form of a patch, can be fixed to the component. Usually a 'belt and braces' approach is taken to ensure safety until the component can be repaired at a later date.



The approved general guidelines for laminate and sandwich repairs should be followed. These repair operations should be carried out in controlled workshop areas to ensure high quality repairs. Good housekeeping and attention to repair detail will ensure success.



For comprehensive inspection of repaired parts a number of Non Destructive Tests (NDT) can be used. The inspector should examine the quality of the repaired area and particular attention should be given to the interface between the original part and the repaired area. Usual inspection methods use some form of ultrasonic test equipment where the reflection of the ultrasonic sound waves detect and identify any damaged areas or faults.

COMPOSITE REPAIR

Typical Damage

Most damage to fibre reinforced composites is a result of low velocity and sometimes high velocity impact. In metals the energy is dissipated through elastic and plastic deformations and still retains a good deal of structural integrity. Whilst in fibre reinforced material the damage is usually more extensive than that seen on the surface.

Delamination following impact on a monolithic laminate

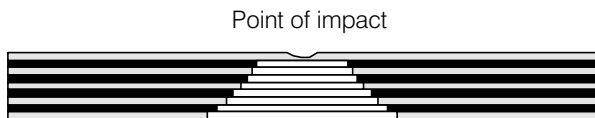

Underlying damage can extend to a much greater extent in laminate structures.

Laminate Splitting

The damage does not extend through the full length of the part. The effects on the mechanical performance depend on the length of split relative to the component thickness.

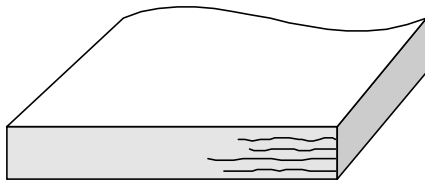

Heat Damage

A local fracture with separation of surface plies. Its effect on the mechanical performance depends on the thickness of the part.

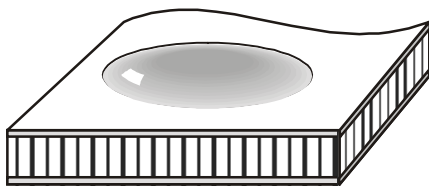

Dents in Sandwich Structure

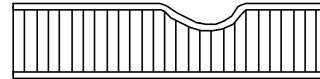

Puncture Damage in a Sandwich Structure

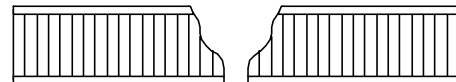

Both skins may be damaged.

Bolt Hole Damage

The damage could be elongation of the hole causing laminate splitting, or damage to the upper plies.

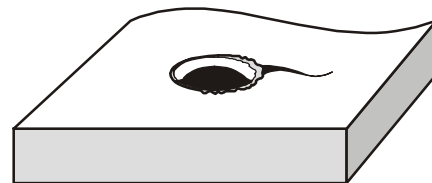

REPAIR OPTIONS

When a composite structure sustains damage in service one of three levels of repair must be employed.

Cosmetic repair

In this case inspection has determined that the damage has not affected the structural integrity of the component. A cosmetic repair is carried out to protect and decorate the surface. This will not involve the use of reinforcing materials.

Temporary or interim repairs

It is often the case in service, that small areas of damage are detected which in themselves do not threaten the integrity or mechanical properties of the component as a whole. However if left unrepaired they may lead to further rapid propagation of the damage through moisture ingress and fatigue.

Simple patch type repairs can be carried out, with the minimum of preparation, to protect the component until it can be taken out of service for a proper structural repair.

Temporary repairs should be subject to regular inspection.

Structural repair

If the damage has weakened the structure through fibre fracture, delamination or disbonding the repair will involve replacement of the damaged fibre reinforcement, and core in sandwich structures, to restore the original mechanical properties. Since a bonded-on repair constitutes a discontinuity of the original plies, and therefore a stress raiser, structural repair schemes normally require extra plies to be provided in the repair area.

If the damaged area is very small it can be questionable whether a structural repair, requiring removal of a substantial amount of the structure in damage removal and preparation, is preferable to a cosmetic repair.

COMPOSITE REPAIR

LAMINATES AND SANDWICH PANELS

The main purpose of a structural repair is to fully support applied loads and transmit applied stresses across the repaired area. To do this the repair materials must overlap, and be adequately bonded to the plies of the original laminate. There are three basic approaches to this.

1. Patch repair

In this case the thickness of the original laminate is made up with filler plies and the repair materials are bonded to the surface of the laminate.

Advantages

- Quick and simple to do
- Requires minimum preparation

Disadvantages

- A repaired laminate is thicker and heavier than the original
- Very careful surface preparation is needed for good adhesion

2. Taper sanded or scarf repair

In this case an area around the hole is sanded to expose a section of each ply in the laminate. Sometimes one filler ply is added to produce a flatter surface. Taper is usually in the region of 30-60:1

Advantages

- Repair is only marginally thicker than the original
- Each repair ply overlaps the ply that it is repairing giving a straighter, stronger load path
- Good bonds can be achieved on the freshly exposed surfaces

Disadvantages

- Time consuming
- High skill needed and difficult to achieve

3. Step sanded repair

The laminate is sanded down so that a flat band of each layer is exposed, producing a stepped finish. Typical steps are 25-50mm per layer.

Advantages

- Same as taper sanded repair

Disadvantages

- Extremely difficult to do

TYPICAL LAMINATE REPAIRS

Note: If the component has been in service it must be dried to remove any moisture to obtain the best repair.

1. Patch repair

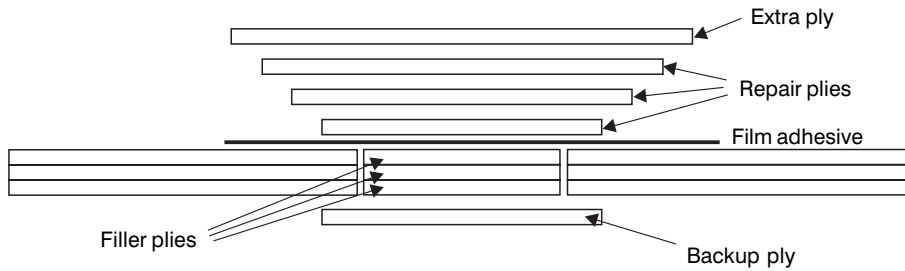

2. Taper sanded repair (Scarf repair)

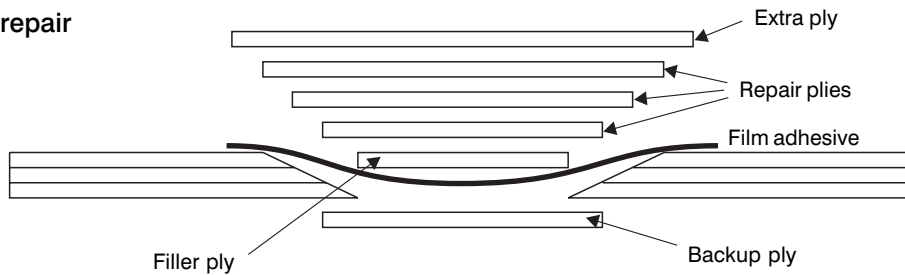

3. Step sanded repair

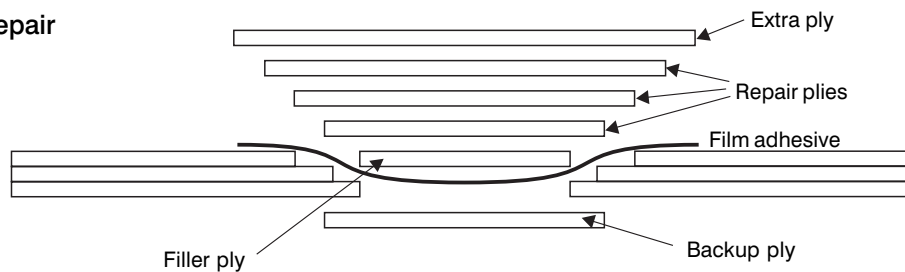

COMPOSITE REPAIR

TYPICAL SANDWICH PANEL REPAIRS

Note: If the component has been in service it must be dried to remove any moisture to obtain the best repair.

1(a) Patch repair

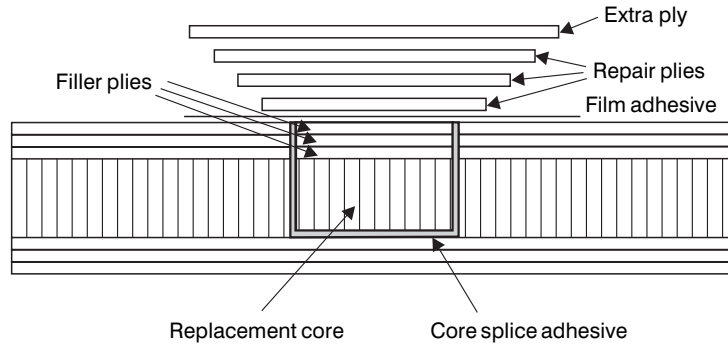

1(b) Alternative patch repair

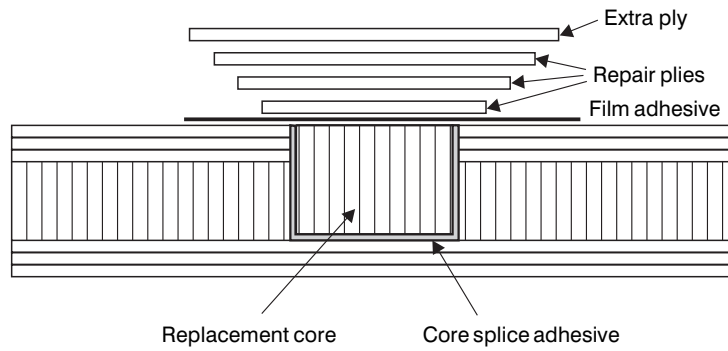

2 Taper sanded repair (scarf repair)

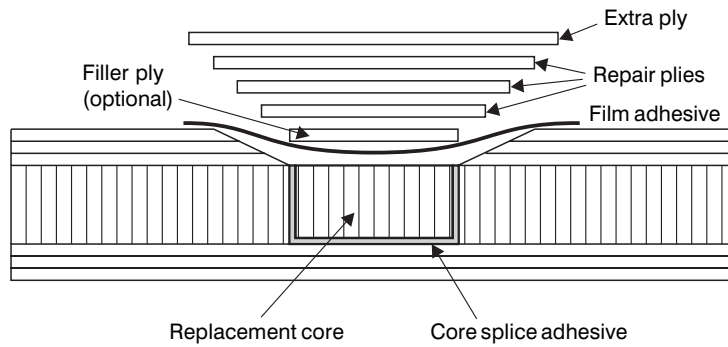

3. Step sanded repair

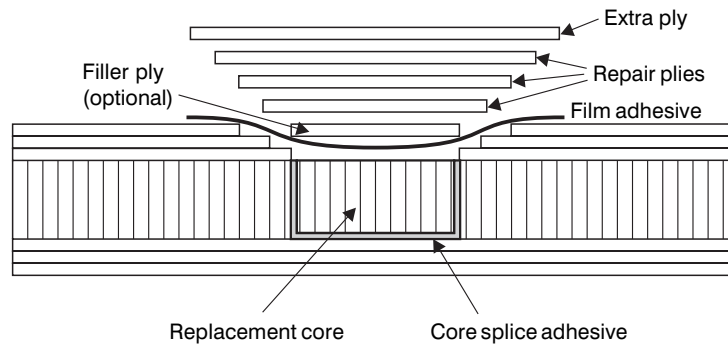

REPAIR SEQUENCE FOR DOUBLE SIDED REPAIR

1. Puncture damage

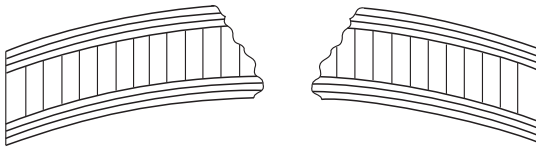

2. Remove damage

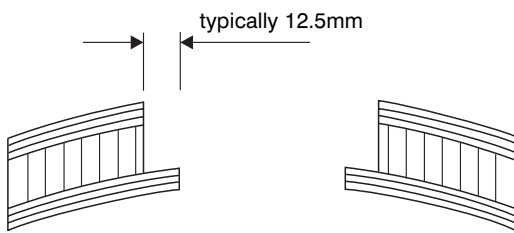

3. Taper sand



4. Bond new honeycomb

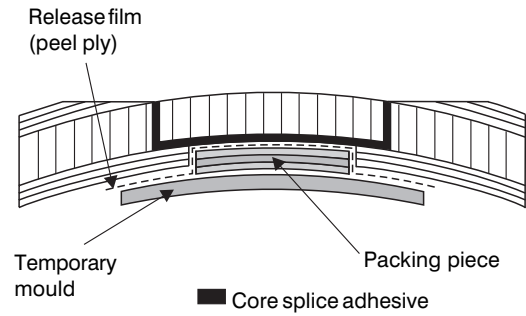

5. Repair first side

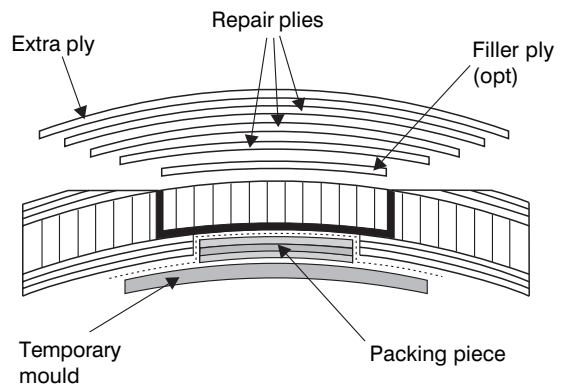

6. Repair second side

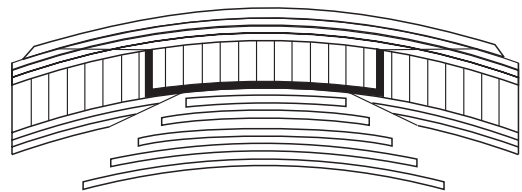

COMPOSITE REPAIR

REPAIR USING PRE-CURED DOUBLER

Some composite repairs can be achieved by the use of pre-cured doublers.

A pre-cured doubler is a sheet of composite material made from layers of fibre reinforced epoxy which has been cured in using heat and pressure.

A patch is cut from the pre-cured material and bonded on to the surface of the component.

The edges of the doubler are chamfered to increase the peel off strength.

Pre-cured doublers can be bonded on to the component using wet lay-up resins or adhesive films. However one major drawback of this method has been entrapment of air under the doubler which leads to a weak repair.

The repair can be improved by using a layer of scrim cloth under the adhesive film to allow the air to escape.

EQUIPMENT AND ANCILLARIES FOR REPAIRS

Typical Layup and Equipment for one side access repair

When access is possible from both sides then a complete envelope bag is recommended.

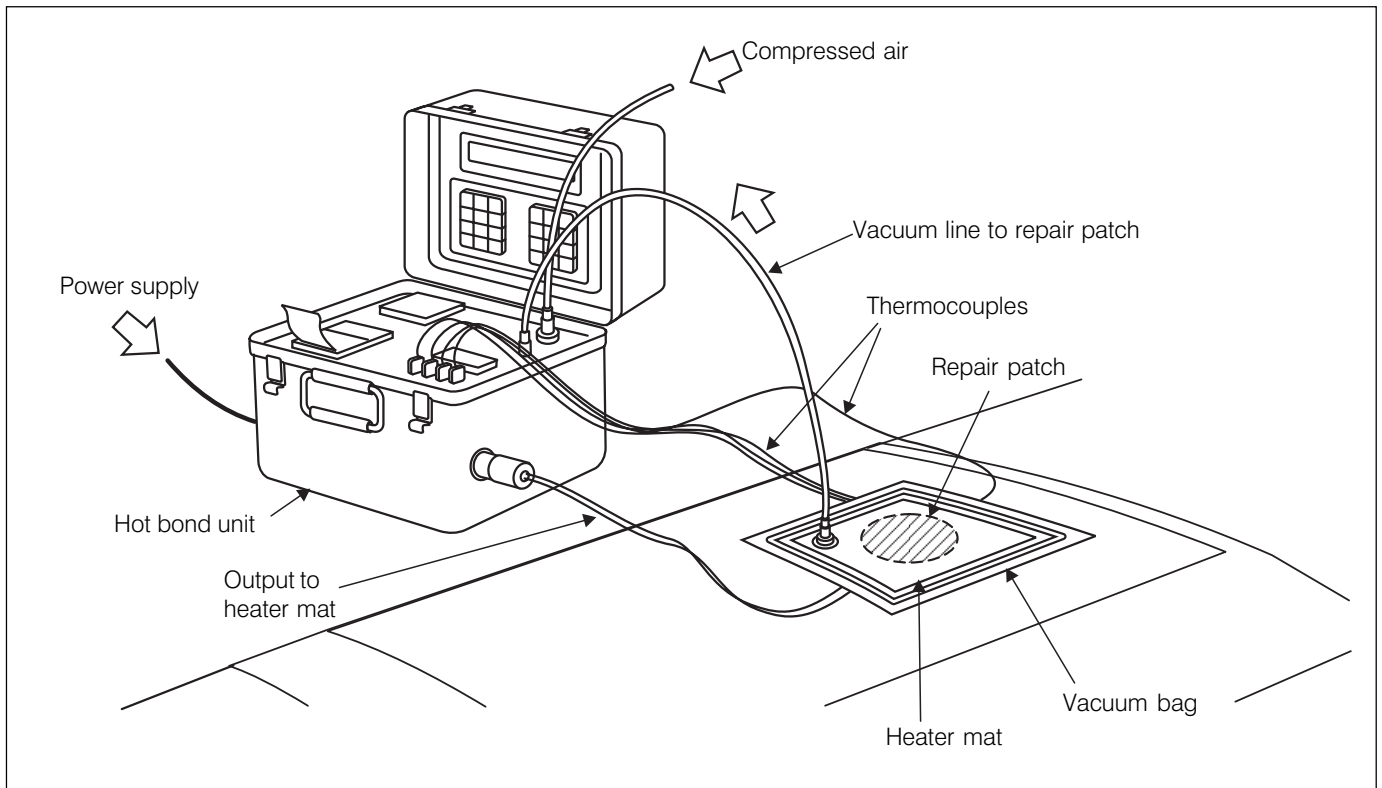

EQUIPMENT AND ANCILLARIES FOR REPAIRS

Hot Bonders

Heater Blankets

Bagging Materials

- vacuum bags
- sealant tape
- release film
- breather
- vacuum take off connector

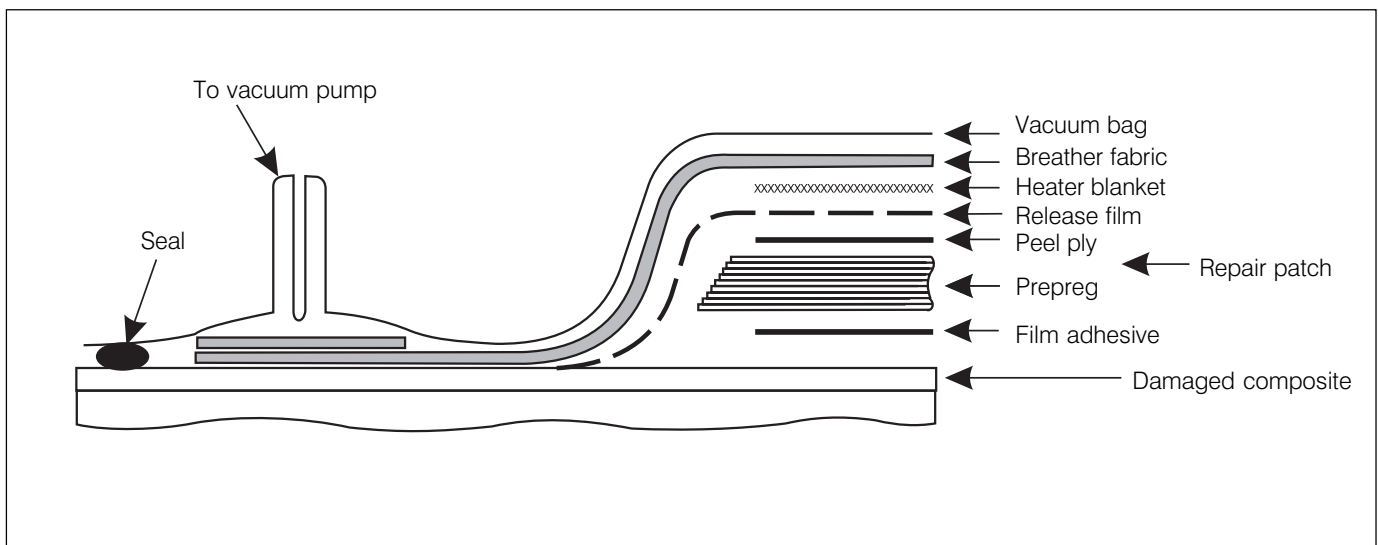

Fig. 1 Detail of vacuum bag lay-up

All the components of a vacuum bag lay-up are shown in the diagram above. This lay-up is ideal for high quality components, however alternative lay-ups are possible to suit the materials and application.

Consumables for Vacuum Bag Processing

Peel ply (optional)

Allows free passage of volatiles and excess matrix during the cure. Can be removed easily after cure to provide a bondable or paintable surface.

Release film

This prevents further flow of matrix and can be slightly porous (with pin pricks) to allow the passage of only air and volatiles into the breather layer above.

Breather fabric

Provides the means to apply the vacuum and assists removal of air and volatiles from the whole assembly. Thicker breathers are needed when high autoclave pressures are used.

Vacuum bag/sealant tape

Provides a sealed bag to allow removal of air to form the vacuum bag.

Note: It is recommended that new consumables are used each time to ensure the manufacture of good quality composites.

COMPOSITE REPAIR

REPAIR PROCESS

Vacuum bag or autoclave - which process?

Vacuum bag and autoclave processing are the two main methods for the repair of components from prepreg. The processing method is determined by the quality, cost and type of component being manufactured.

Processing method	Component		Processing costs	
	Quality	Section thickness	Equipment cost	Cure cycle time
Vacuum bag	Good	Thin	Moderate	Short
Autoclave	Excellent	Thick	High	Long

Vacuum bag processing is suited to components with thin sections and large sandwich structures. The vacuum bag technique involves the placing and sealing of a flexible bag over a composite lay-up (fig. 1) and evacuating all the air from under the bag (fig. 2).

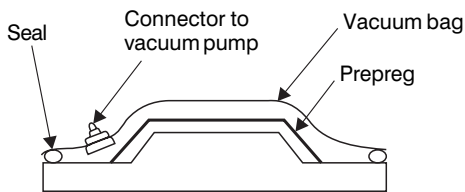

Fig. 2 Sealing flexible bag over lay-up

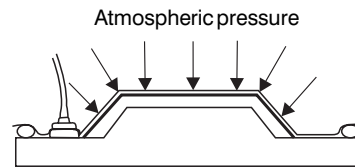

Fig. 3 Applying vacuum to the system

The removal of air forces the bag down onto the lay-up with consolidation pressure of 1 atmosphere (1 bar). The completed assembly, with vacuum still applied, is placed inside an oven with good air circulation, and the composite is produced after a relatively short cycle cure.

Autoclave processing is used for the repair of high quality structural components. The autoclave technique requires a similar vacuum bag (fig.1) but the oven is replaced by an autoclave. The autoclave is a pressure vessel which provides the curing conditions for the composite where the application of vacuum, pressure, heat up rate and cure temperature are controlled. High processing pressures allow the moulding of thicker sections of complex shapes. Honeycomb sandwich structures can also be made to a high standard. Long cure cycles are required because the large autoclave mass takes a long time to heat up and cool down. Sometimes slow heat up rates are required to guarantee even temperature distribution on the tooling and composite components.

HEXCEL'S PRODUCTS FOR COMPOSITE REPAIR

Hexcel is the leading worldwide supplier of composite materials for aerospace, sports goods, marine, rail and automotive applications.

Hexcel manufactures a range of composite materials, which are ideally suited for the repair of composites. These include:

- A wide selection of prepregs, including the new M20, 130°C curing system for vacuum bag or autoclave processing (qualified to RMS 167).
- Redux® structural film adhesives
- Aluminium, Nomex® and specialist honeycombs
- Modipur® polyurethane foams

(Nomex is a registered trademark of Du Pont).

Important

All information is believed to be accurate but is given without acceptance of liability. Users should make their own assessment of the suitability of any product for the purposes required. All sales are made subject to our standard terms of sale which include limitations on liability and other important terms.

With thanks to Aeroskills for assistance with selected drawings in this manual.